

# R5 KB 0010/0016 E

Oil-lubricated rotary vane vacuum pumps



VACUUM SOLUTIONS



## Compact

Direct-drive construction, reduced height and weight, ideal for installation in vacuum packaging machines

## Reliable

Robust construction, highly durable vanes, proven rotary vane technology, long service life

## Flexible

Various design options available, easy adaption to individual customer requirements and processes

### Accessories

- Gas-ballast valve
- Filter pressure gauge
- Vacuum pump oils for all applications
- Various inlet filters
- Oil level switch
- Vacuum regulating unit

# R5 KB 0010/0016 E

Oil-lubricated rotary vane vacuum pumps



VACUUM SOLUTIONS

Dimensional drawing

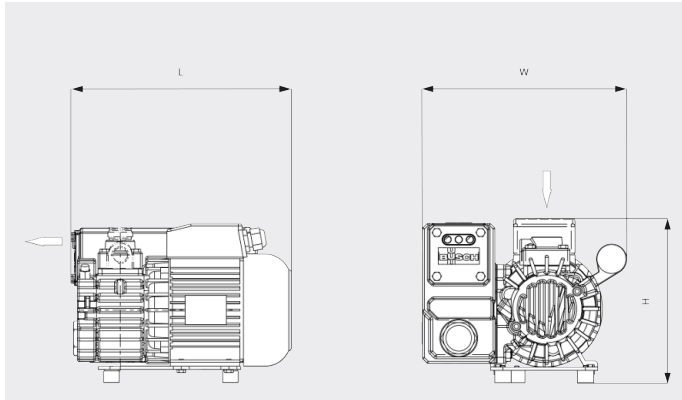

Pumping speed

Air at 70°F. Tolerance: ± 10%

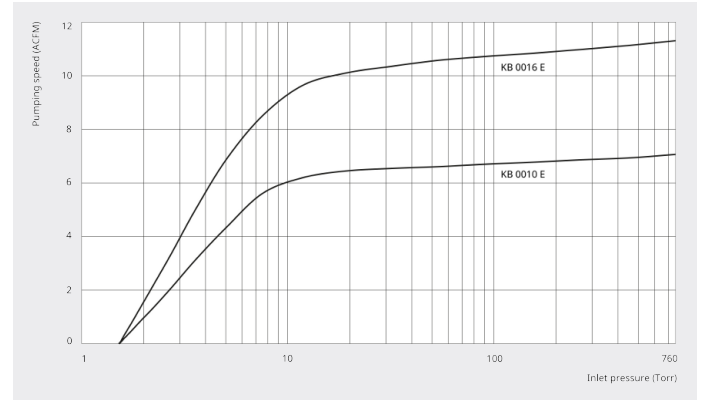

	R5 KB 0010 E	R5 KB 0016 E
Nominal pumping speed	7.1 ACFM	11.2 ACFM
Ultimate pressure	1.5 TORR	1.5 TORR
Nominal motor rating	0.5 HP	0.7 HP
Nominal motor speed	3600 RPM	3600 RPM
Noise level (ISO 2151)	67 dB(A)	68 dB(A)
Oil capacity	0.3 qts.	0.3 qts.
Weight approx.	35.2 Lbs.	39.6 Lbs.
Dimensions (L x W x H)	10.7 x 8.6 x 7.9 inches	11.9 x 8.5 x 7.9 inches
Gas inlet	G 3/4"	G 3/4"

## DO YOU WANT TO KNOW MORE?

Get in touch with us directly!  
[info@buschusa.com](mailto:info@buschusa.com) or +1 757 463 7800



CONTACT FORM



CALL NOW